

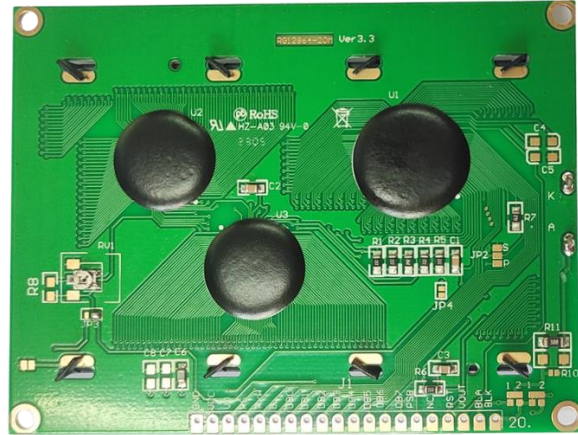

# RG12864 Serial Interface Display 128×64 BLUE



## 1. Features:

The features of LCD are as follows:

- Display mode : STN /BLUE, NEGATIVE, TRANSMISSIVE
- Colour : Display dot : WHITE  
Background: BLUE
- Display Format : 128 (characters) × 64 (line)
- \* IC : ST7920 ST7921
- Interface Input Data : 8 Bits
- Driving Method : 1/65 Duty, 1/9 Bias
- Viewing Direction: 6 O'clock
- Backlight : LED (WHITE)

## 2. Mechanical Specifications:

Item	Specification	Unit
Module Size	93.00(W) X70.00(H) X12.5(T)	mm
Viewing Area	72.00(W) X 39.90(H)	mm
Effective Display Area	66.52(W) X 33.24(H)	mm
Number of Dots	128 X 64 Dots	-
Dot Size	0.48(W) X 0.48(H)	mm
Dot Pitch	0.52(W) X 0.52(H)	mm

### 3. Electrical Specifications:

#### 1. Absolute Maximum Ratings (V<sub>SS</sub> = 0V)

Item	Symbol	Standard Value			Unit
		Min.	Typ.	Max.	
Supply Voltage For Logic	V <sub>DD</sub>	-0.3	-	5.0	V
Supply Voltage For LCD Drive	V <sub>0</sub> , V <sub>OUT</sub>	-0.3	-	14.5	V
Operating Temp.	T <sub>OP</sub>	-20	-	+70	°C
Storage Temp.	T <sub>ST</sub>	-30	-	+80	°C
Static Electricity	Be sure that you are ground when handing LCM				

#### 2. Electrical Characteristics:

Item		Symbol	Test Condition	Min.	Typ.	Max.	Unit
Supply Voltage For Logic		V <sub>DD</sub> – V <sub>SS</sub>	T <sub>a</sub> =25°C	4.7	5.0	5.3	V
Supply Voltage For LCD		V <sub>DD</sub> – V <sub>0</sub>	T <sub>a</sub> =25°C	-	-	-	V
Input Voltage	“H” Level	V <sub>IH</sub>	T <sub>a</sub> =25°C	0.8V <sub>DD</sub>	-	V <sub>DD</sub>	V
	“L” Level	V <sub>IL</sub>		V <sub>SS</sub>	-	0.2V <sub>DD</sub>	V
Output Voltage	“H” Level	V <sub>OH</sub>	I <sub>OUT</sub> = -0.5mA	0.8V <sub>DD</sub>	-	V <sub>DD</sub>	V
	“L” Level	V <sub>OL</sub>	I <sub>OUT</sub> = 0.5mA	V <sub>SS</sub>	-	0.2V <sub>DD</sub>	V
Current Consumption		I <sub>DD</sub>	V <sub>IN</sub> = V <sub>DD</sub>	-	-	1.0	mA

NOTE: 1) Duty ratio=1/65, Bias=1/9  
2) Measured in Dots ON-state

### 3. BACKLIGHT:

#### 3.1 Absolute Maximum Ratings:

Item	Symbol	Condition	Min.	Typ.	Max	Unit
Forward Current	IF	Ta= 25°C	-	-	20	mA
Reverse Voltage	VR		-	-	5	V
Power Dissipation	PD	Ta= 25°C	-	-	100	mW

#### 3.2 Opto-electronic Characteristics:

Item	Symbol	Condition	Min.	Typ.	Max	Unit
Forward Voltage	VF	Ta= 25°C IF= 60mA	2.8	3.0	3.2	V
Luminous	-		100	150	-	cd/m <sup>2</sup>

*\* The brightness is measured without LCD panel*

**4. Schematic Design:**

**BLOCK DIAGRAM**

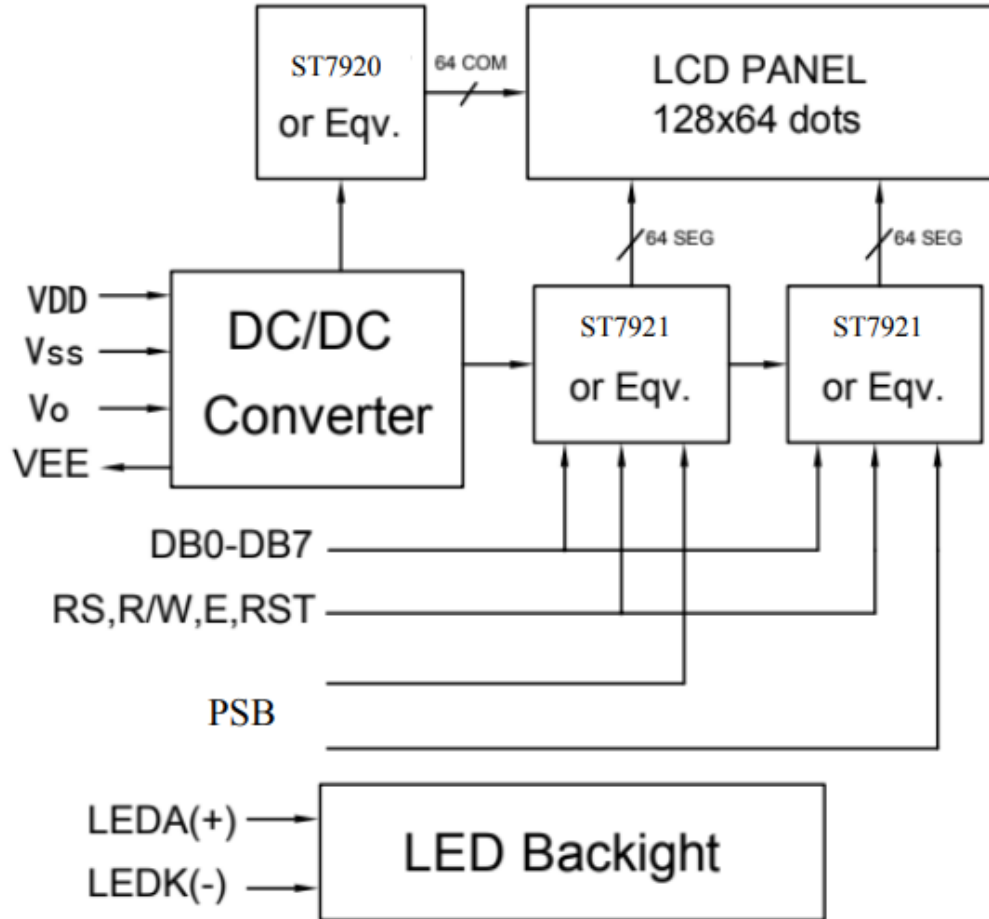

**5. Interface Pin Function:**

Pin	Symbol	Level	Function
1	Vss	--	GND (0V)
2	VDD	--	Supply Voltage for Logic (+5v)
3	Vo	--	Power supply for LCD
4	RS	H/L	H:Data L:Instruction code
5	R/W	H/L	H:Read L:Write
6	E	H	Enable Signal
7	DB0	H/L	Data Bus Line
8	DB1	H/L	
9	DB2	H/L	
10	DB3	H/L	
11	DB4	H/L	
12	DB5	H/L	
13	DB6	H/L	
14	DB7	H/L	
15	PSB	H/L	Interface selection: 0: serial mode; 1: 8/4-bit parallel bus mode.
16	NC		
17	RESET	H/L	Reset Signal
18	VEE	--	Negative Voltage(-10V)to LCD
19	LED+	--	LED Backlight Power Supply +5V
20	LED-	--	

## 6. Command List:

ST7920 offers basic instruction set and extended instruction set:

### Instruction Set 1: (RE=0: Basic Instruction)

Inst.	Code										Description	Exec time (540KHZ)
	RS	RW	DB7	DB6	DB5	DB4	DB3	DB2	DB1	DB0		
Display Clear	0	0	0	0	0	0	0	0	0	1	Fill DDRAM with "20H" and set DDRAM address counter (AC) to "00H".	1.6 ms
Return Home	0	0	0	0	0	0	0	0	1	X	Set DDRAM address counter (AC) to "00H", and put cursor to origin : the content of DDRAM are not changed	72 us
Entry Mode Set	0	0	0	0	0	0	0	1	I/D	S	Set cursor position and display shift when doing write or read operation	72 us
Display Control	0	0	0	0	0	0	1	D	C	B	D=1: Display ON C=1: Cursor ON B=1: Character Blink ON	72 us
Cursor Display Control	0	0	0	0	0	1	S/C	R/L	X	X	Cursor position and display shift control; the content of DDRAM are not changed	72 us
Function Set	0	0	0	0	1	DL	X	0	X	X	DL=1 8-bit interface DL=0 4-bit interface <b>RE=1: extended instruction</b> <b>RE=0: basic instruction</b>	72 us
Set CGRAM Address.	0	0	0	1	AC5	AC4	AC3	AC2	AC1	AC0	Set CGRAM address to address counter (AC) <b>Make sure that in extended instruction SR=0 (scroll or RAM address select)</b>	72 us
Set DDRAM Address.	0	0	1	0	AC5	AC4	AC3	AC2	AC1	AC0	Set DDRAM address to address counter (AC) AC6 is fixed to 0	72 us
Read Busy Flag (BF) & AC.	0	1	BF	AC6	AC5	AC4	AC3	AC2	AC1	AC0	Read busy flag (BF) for completion of internal operation, also Read out the value of address counter (AC)	0 us
Write RAM	1	0	D7	D6	D5	D4	D3	D2	D1	D0	Write data to internal RAM (DDRAM/CGRAM/GDRAM)	72 us
Read RAM	1	1	D7	D6	D5	D4	D3	D2	D1	D0	Read data from internal RAM (DDRAM/CGRAM/GDRAM)	72 us

**Instruction set 2: (RE=1: extended instruction)**

Inst.	Code										Description	Exec time (540KHZ)	
	RS	RW	DB7	DB6	DB5	DB4	DB3	DB2	DB1	DB0			
Standby	0	0	0	0	0	0	0	0	0	1	Enter standby mode, any other instruction can terminate. COM1...32 are halted.	72 us	
Scroll or RAM Address. Select	0	0	0	0	0	0	0	0	1	SR	SR=1: enable vertical scroll position SR=0: enable CGRAM address ( <b>basic instruction</b> )	72 us	
Reverse (by line)	0	0	0	0	0	0	0	1	R1	R0	Select 1 out of 4 line (in DDRAM) and decide whether to reverse the display by toggling this instruction <b>R1,R0 initial value is 0,0</b>	72 us	
Extended Function Set	0	0	0	0	1	DL	X	1	RE	G	0	DL=1 :8-bit interface DL=0 :4-bit interface <b>RE=1: extended instruction set</b> <b>RE=0: basic instruction set</b> G=1 :graphic display ON G=0 :graphic display OFF	72 us
Set Scroll Address	0	0	0	1	AC5	AC4	AC3	AC2	AC1	AC0	SR=1: AC5~AC0 the address of vertical scroll	72 us	
Set Graphic Display RAM Address	0	0	1	0	0	0	AC3	AC2	AC1	AC0	0	Set GDRAM address to address counter (AC) Set the vertical address first and followed the horizontal address by consecutive writings Vertical address range: AC5...AC0 Horizontal address range: AC3...AC0	72 us

**Note:**

1. Make sure that ST7920 is not in busy state by reading the busy flag before sending instruction or data. If using delay loop instead, please make sure the delay time is enough. Please refer to the instruction execution time.
2. "RE" is the selection bit of basic and extended instruction set. After setting the RE bit, the value will be kept. So that the software doesn't have to set RE every time when using the same instruction set.



DDRAM data (char. code)				CGRAM Addr.				CGRAM data (higher byte)				CGRAM data (lower byte)																	
B15~ B4	B3	B2	B1	B5	B4	B3	B2	B1	B0	D11	D10	D9	D8	D7	D6	D5	D4	D3	D2	D1	D0								
0	X	00	X	00	0	0	0	0	0	0	0	0	1	0	0	0	1	1	0	0	0	0							
					0	0	0	1	1	1	1	1	1	0	0	1	0	0	0	0	0	0	0	0	0	0			
					0	0	1	0	0	0	1	0	0	0	0	0	0	0	1	0	0	0	1	0	0	0	0		
					0	0	1	1	0	0	0	1	0	0	0	0	0	0	1	1	1	1	1	1	0	0	0		
					0	1	0	0	0	0	1	0	0	1	0	0	1	0	0	1	0	0	0	0	1	0	0	0	
					0	1	0	1	0	0	1	1	1	1	0	0	1	0	0	0	0	0	1	0	0	0	1	0	0
					0	1	1	0	0	1	0	0	1	0	1	0	1	0	1	0	1	0	0	1	0	0	0	0	0
					0	1	1	1	1	0	1	0	0	1	1	0	0	1	0	0	1	0	0	1	0	0	0	0	0
					1	0	0	0	0	0	1	0	0	1	0	0	0	1	0	0	0	1	0	0	1	0	0	0	0
					1	0	0	1	0	0	1	0	0	1	0	0	0	0	0	0	0	0	0	1	0	0	0	0	0
					1	0	1	0	0	0	1	0	0	1	0	0	0	0	0	0	0	0	0	1	0	0	0	0	0
					1	0	1	1	0	0	1	1	1	1	0	0	0	0	0	0	0	0	0	1	0	0	0	0	0
					1	1	0	0	0	0	1	0	0	1	0	0	0	0	0	0	0	0	0	1	0	0	0	0	0
					1	1	0	1	0	0	0	0	0	0	0	0	0	0	0	0	0	0	0	1	0	0	0	0	0
					1	1	1	0	0	0	0	0	0	0	0	0	0	0	0	0	0	0	0	0	0	0	0	0	0
					1	1	1	1	0	0	0	0	0	0	0	0	0	0	0	0	0	0	0	0	0	0	0	0	0

**Table 5: DDRAM data (character code) vs. CGRAM data/address map**

### 7. Timing Characteristics (Continued):

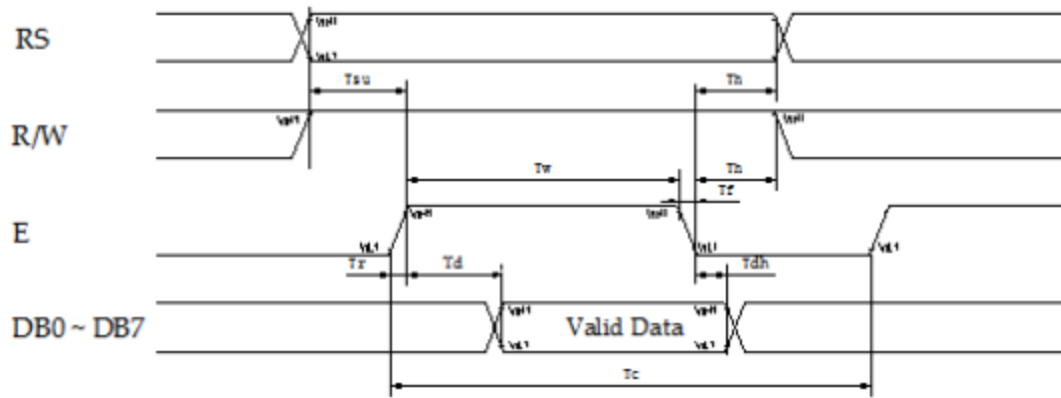

Figure 7. Read Mode Timing Diagram

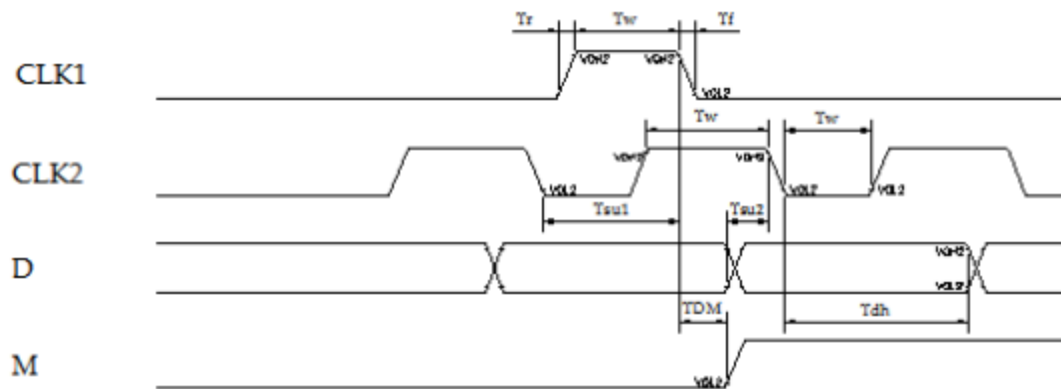

Figure 8. Interface Mode With Extension Driver Timing Diagram

**AC Characteristics ( $T_A = -30^{\circ}\text{C} \sim 85^{\circ}\text{C}$ ,  $V_{DD} = 4.5\text{V}$ ) Serial Mode Interface**

Symbol	Characteristics	Test Condition	Min.	Typ.	Max.	Unit
<i>Internal Clock Operation</i>						
$f_{OSC}$	OSC Frequency	$R = 33\text{K}\Omega$	470	530	590	KHz
<i>External Clock Operation</i>						
$f_{EX}$	External Frequency	-	470	530	590	KHz
	Duty Cycle	-	45	50	55	%
$T_{R}, T_{F}$	Rise/Fall Time	-	-	-	0.2	$\mu\text{s}$
$T_{SCYC}$	Serial clock cycle	Pin E	400	-	-	ns
$T_{SHW}$	SCLK high pulse width	Pin E	200	-	-	ns
$T_{SLW}$	SCLK low pulse width	Pin E	200	-	-	ns
$T_{SDS}$	SID data setup time	Pins RW	40	-	-	ns
$T_{SDH}$	SID data hold time	Pins RW	40	-	-	ns
$T_{CSS}$	CS setup time	Pins RS	60	-	-	ns
$T_{CSH}$	CS hold time	Pins RS	60	-	-	ns

**AC Characteristics ( $T_A = -30^{\circ}\text{C} \sim 85^{\circ}\text{C}$ ,  $V_{DD} = 2.7\text{V}$ ) Serial Mode Interface**

Symbol	Characteristics	Test Condition	Min.	Typ.	Max.	Unit
<i>Internal Clock Operation</i>						
$f_{OSC}$	OSC Frequency	$R = 18\text{K}\Omega$	470	530	590	KHz
<i>External Clock Operation</i>						
$f_{EX}$	External Frequency	-	470	530	590	KHz
	Duty Cycle	-	45	50	55	%
$T_{R}, T_{F}$	Rise/Fall Time	-	-	-	0.2	$\mu\text{s}$
$T_{SCYC}$	Serial clock cycle	Pin E	600	-	-	ns
$T_{SHW}$	SCLK high pulse width	Pin E	300	-	-	ns
$T_{SLW}$	SCLK low pulse width	Pin E	300	-	-	ns
$T_{SDS}$	SID data setup time	Pins RW	40	-	-	ns
$T_{SDH}$	SID data hold time	Pins RW	40	-	-	ns
$T_{CSS}$	CS setup time	Pins RS	60	-	-	ns
$T_{CSH}$	CS hold time	Pins RS	60	-	-	ns

## 8. Quality Specification (Continued):

### 8-3. Sampling Plan and Acceptance

#### 1. Sampling Plan

MIL - STD - 105E ( II ) ordinary single inspection is used.

#### 2. Acceptance

Major defect:                      AQL = 0.25%

Minor defect:                      AQL = 0.65%

### 8-4. Criteria

#### a) COB

Defect	Inspection Item	Inspection Standards	
Major	PCB copper flakes peeling off	Any copper flake in viewing Area should be greater than 1.0mm <sup>2</sup>	Reject
Major	Height of coating epoxy	Exceed the dimension of drawing	Reject
Major	Void or hole of coating epoxy	Expose bonding wire or IC	Reject
Major	PCB cutting defect	Exceed the dimension of drawing	Reject

#### b) SMT

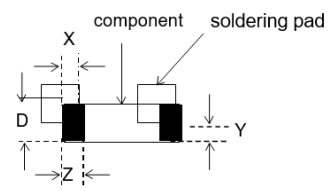
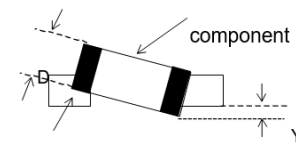
Defect	Inspection Item	Inspection Standards	
Minor	Component marking not readable		Reject
Minor	Component height	Exceed the dimension Of drawing	Reject
Major	Component solder defect (missing , extra, wrong component or wrong orientation		Reject
Minor	 <p>Component position shift</p>	$X < 3/4Z$ $Y > 1/3D$	Reject Reject
Minor	 <p>Component tilt</p>	$Y > 1/3D$	Reject

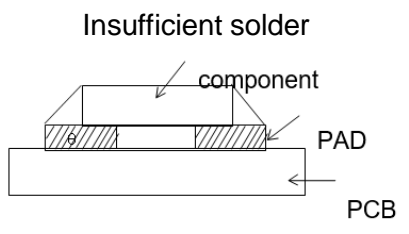
Minor		$\theta \leq 20^\circ$	Reject
-------	---	------------------------	--------

### 3. Metal (Plastic) Frame

Defect	Inspection Item	Inspection Standards		
Major	Crack / breakage	Anywhere		Reject
Minor	Frame Scratch	W	L	Acceptable of Scratch
		$w < 0.03\text{mm}$	Any	Ignore
		$0.03\text{mm} \leq w < 0.05\text{mm}$	$L \leq 5.0\text{mm}$	2
		$0.05\text{mm} < w < 0.1\text{mm}$	$L < 3.0\text{mm}$	1
		$w > 0.1\text{mm}$	Any	0
Note: 1. Above criteria applicable to scratch lines with distance greater than 5mm. 2. Scratch on the back side of frame (not visible) can be ignored.				
Minor	Frame Dent, Prick $\Phi = \frac{L + W}{2}$			Acceptable of Dents / Pricks
		$\Phi \leq 1.0\text{mm}$		2
		$1.0 < \Phi \leq 1.5\text{mm}$		1
		$1.5\text{mm} > \Phi$		0
Note: 1. Above criteria applicable to any two dents / pricks with distance greater than 5mm 2. Dent / prick on the back side of frame (not visible) can be ignored				
Minor	Frame Deformation	Exceed the dimension of drawing		
Minor	Metal Frame Oxidation	Any rust		

#### 4. Flexible Film Connector (FFC)

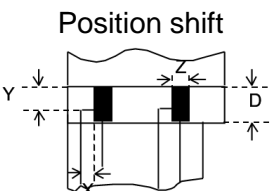
Defect	Inspection Item		Inspection Standards	
Minor	Tilted soldering		Within the angle $\pm 3^\circ$	Acceptable
Minor	Uneven solder joint /bump			Reject
Minor	Hole	$\Phi = \frac{L + W}{2}$	Expose the conductive line	Reject
			$\Phi > 1.0\text{mm}$	Reject
Minor	Position shift 		$Y > 1/3D$	Reject
			$X > 1/2Z$	Reject

#### 5. Screw

Defect	Inspection Item	Inspection Standards	
Major	Screw missing/loosen		Reject
Minor	Screw oxidation	Any rust	Reject
Minor	Screw deformation	Difficult to accept screw driver	Reject

#### 6. Heat seal 、 TCP 、 FPC

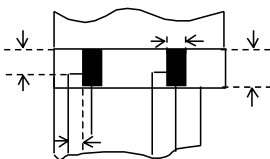
Defect	Inspection Item		Inspection Standards	
Major	Scratch expose conductive layer			Reject
Minor	HS Hole	$\Phi = \frac{L + W}{2}$	$\Phi > 0.2\text{mm}$	Reject
Major	Adhesion strength		Less than the specification	Reject
Minor	Position shift 		$Y > 1/3D$	Reject
			$X > 1/2Z$	Reject
Major	Conductive line break			Reject

**7. LED Backing Protective Film and Others**

Defect	Inspection Item	Inspection Standards	
Minor	LED dirty, prick	Acceptable number of units	
		$\Phi \leq 0.10\text{mm}$	Ignore
		$0.10 < \Phi \leq 0.15\text{mm}$	2
		$0.15 < \Phi \leq 0.2\text{mm}$	1
		$\Phi > 0.2\text{mm}$	0
		The distance between any two spots should be $\geq 10\text{mm}$ Any spot/dot/void outside of viewing area is acceptable	
Minor	Protective film tilt	Not fully cover LCD	Reject
Major	COG coating	Not fully cover ITO circuit	Reject

**8. Electric Inspection**

Defect	Inspection Item	Inspection Standards	
Major	Short		Reject
Major	Open		Reject

## 9. Inspection Specification of LCD

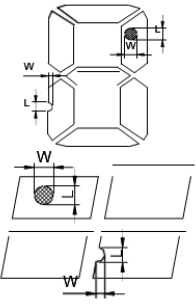
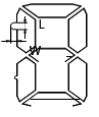
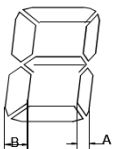
Defect	Inspect Item	Inspection Standards					
		W	W<0.03	0.03<W<0.05	W>0.05		
Minor	Linear Defect	* Glass Scratch	L	L<5	L<3	Any	
		* Polarizer Scratch	ACC. NO.	1	1	Reject	
		* Fiber and Linear material	Note	L is the length and W is the width of the defect			
Minor	Black Spot and Polarizer Pricked	* Foreign material between glass and polarizer or glass and glass	Φ	Φ≤0.1	0.1<Φ≤0.15	0.15<Φ≤0.2	Φ>0.2
		* Polarizer hole or protuberance by external force	ACC. NO.	3EA /1PC	2	1	0
			Note	Φ is the average diameter of the defect.Distance between two defects > 10mm.			
Minor	White Spot and Bubble in polarizer	* Unobvious transparent foreign material between glass and glass or glass and polarizer	Φ	Φ≤0.1	0.1<Φ≤0.15	0.15<Φ≤0.2	Φ>0.2
		* Air protuberance between polarizer and glass	ACC. NO.	3EA / 1PC	2	1	0
			Note	Φ is the average diameter of the defect.Distance between two defects > 10mm.			
Minor	Segment Defect		Φ	Φ≤0.10	0.10<Φ≤0.20	Φ>0.2	
			ACC. NO.	3EA /1PC	2	0	
					W is more than 1/2 segment width	Reject	
			Note	$\Phi = \frac{L + W}{2}$ Distance between two defect is 10mm			
Minor	Protuberant Segment	 $\Phi = (L + W) / 2$	Φ	Φ≤0.10	0.10<Φ≤0.20	Φ>0.2	
			W	Glue	W≤1/2 Seg , W≤0.2	Ignore	
			ACC. NO.	3EA /1PC	2	0	
Minor	Assembly Misalignment		1. Segment				
			B	B≤0.4mm	0.4<B≤1.0mm	B>1.0mm	
			B-A	B-A<1/2B	B-A<0.2	B-A<0.25	
			Judge	Acceptable	Acceptable	Acceptable	
		2. Dot Matrix					
			Deformation>0.35mm			Reject	



Minor	Stain on LCD Panel Surface		Accept when stains can be wiped lightly with a soft cloth or a similar one. Otherwise, judged according to the above items: "Black spot" and "White Spot"
-------	----------------------------	--	---

## 9. Reliability:

NO.	Item	Condition	Criterion
1	High Temperature Operating	70°C, 96Hrs	No defect in cosmetic and operational function allowable.
2	Low Temperature Operating	-20°C, 96Hrs	
3	High Humidity	40°C, 90%RH, 96Hrs	
4	High Temperature Storage	80°C, 96Hrs	
5	Low Temperature Storage	-30°C, 96Hrs	
6	Vibration	Random wave 10 ~ 100Hz Acceleration: 2g 2 Hrs per direction(X,Y,Z)	Total current Consumption should be below double of initial value.
7	Thermal Shock	-10°C to 25°C to 60°C (60Min) (5Min) (60Min) 16Cycles	
8	ESD Testing	Contract Discharge Voltage: +1 ~ 5kV and -1 ~ -5kV	There will be discharged ten times at every discharging voltage cycle. The voltage gap is 1kV.
		Air Discharge Voltage: +1 ~ 8kV and -1 ~ -8kV	

- Note:**
- 1) Above conditions are suitable for XIN NUO YA standard products.
  - 2) For restrict products, the test conditions listed as above must be revised.

## 10. Handling Precaution:

### (1) Mounting Method

The panel of the LCD Module consists of two thin glass plates with polarizers which easily get damaged since the Module is fixed by utilizing fitting holes in the printed circuit board. Extreme care should be taken when handling the LCD Modules.

### (2) Caution of LCD handling & cleaning

When cleaning the display surface, use soft cloth with solvent (recommended below) and wipe lightly.

- Isopropyl alcohol
- Ethyl alcohol
- Trichlorotrifluoroethane

Do not wipe the display surface with dry or hard materials that will damage the polarizer surface.

Do not use the following solvent:

- Water
- Ketone
- Aromatics

### (3) Caution against static charge

The LCD Module use C-MOS LSI drivers, so we recommend that you connect any unused input terminal to VDD or VSS, do not input any signals before power is turned on. And ground your body, Work/assembly table. And assembly equipment to protect against static electricity.

### (4) Packaging

- Modules use LCD elements, and must be treated as such. Avoid intense shock and falls from a height.
- To prevent modules from degradation. Do not operate or store them exposed directly to sunshine or high temperature/humidity.

### (5) Caution for operation

- It is indispensable to drive LCD's within the specified voltage limit since the higher voltage than the limit shorten LCD life. An electrochemical reaction due to direct current causes LCD deterioration, Avoid the use of direct current drive.

## Handling Precaution (Continued):

- Response time will be extremely delayed at lower temperature than the operating temperature range and on the other hand at higher temperature LCD's show darkcolor in them. However those phenomena do not mean malfunction or out of order with LCD's. Which will come back in the specified operating temperature range.
- If the display area is pushed hard during operation, some font will be abnormally displayed but it resumes normal condition after turning off once.
- A slight dew depositing on terminals is a cause for electro-chemical reaction resulting in terminal open circuit.

Usage under the relative condition of 60°C, 90%RH or less is required.

### (6) Storage

In the case of storing for a long period of time (for instance, for years) for the purpose or replacement use, The following ways are recommended.

- Storage in a polyethylene bag with sealed so as not to enter fresh air outside in it, And with no desiccant.
- Placing in a dark place where neither exposure to direct sunlight nor light is.

Keeping temperature in the specified storage temperature range.

- Storing with no touch on polarizer surface by the anything else. (It is recommended to store them as they have been contained in the inner container at the time of delivery)

### (7) Safety

- It is recommendable to crash damaged or unnecessary LCD into pieces and wash off liquid crystal by using solvents such as acetone and ethanol.

Which should be burned up later.

When any liquid crystal leaked out of a damaged glass cell comes in contact with your hands, please wash it off well with soap and water.

## 11. Outline Dimensions:

